

Media kit 2012

valid from 01/12/2011



PDF-Download



GEBÄUDEDIGITAL

Electrical installation and building technology in the 21st century

Content

Contact information		3
Topics	Regular topics	4
	Editorial calendar	5
Concept and distribution		9
Prices	Sizes	11
	Inserts and supplements	14
Special supplement	Solar technology	13
Special supplement	Security technology	14
Advertising forms		15
Special advertising forms	Company-/Product portrait	16
	Reprint	17
	Special placements	18
Newsletter		19
Website	Banner sizes and prices	20
	Producer microsites	22
	Logo placements	24
Technical data	Advertisement sizes	25
	Advertisements	26
	Supplements	27
	Inserts	28
General terms and conditions		29

Publishing company

Technik-Dokumentations-Verlag GmbH
 Postfach 2140, 35009 Marburg
 Zu den Sandbeeten 2, 35043 Marburg
 (for deliveries only)

Phone +49 6421 3086-0
 Fax +49 6421 3086-28
 Internet www.gebaeuedigital.de
 E-Mail info@gebaeuedigital.de



Your Contact persons



Editor-in-chief
 Kai Binder
kbinder@gebaeuedigital.de
 Phone: +49 6421 308-639
 Fax: +49 6421 308-6539



Editor director
 Henning Schulz
hschulz@gebaeuedigital.de
 Phone: +49 6421 308-627
 Fax: +49 6421 308-6527



Editorial assistant
 Carolin Sachse
csachse@gebaeuedigital.de
 Phone: +49 6421 308-626
 Fax: +49 6421 308-6526



Marketing director
 Richard Sturm
rsturm@gebaeuedigital.de
 Phone: +49 6421 308-623
 Fax: +49 6421 308-6523



Marketing
 Alexandra Ferdinand
aferdinand@gebaeuedigital.de
 Tel.: +49 6421 308-6598
 Fax: +49 6421 308-6508



Marketing
 Konstantin Kiy
kkiy@gebaeuedigital.de
 Phone: +49 6421 308-624
 Fax: +49 6421 308-6524

Our regular topics:

Home- & Building Automation

- Field busses/network logs: KNX, BACnet, LON, EnOcean, LCN, Dali etc.
- Operating and monitoring in buildings
- Electrical drive technology
- Building automation for industrial and non living space
- Building control, telecontrol solutions
- Smart house-control systems and controlpanels
- Radio-based solutions for home automation

Security & Surveillance

- Alert- and video surveillance
- Security- and emergency lightening
- Fire- and intrusion detection systems
- Access control systems/time recording
- Door communication/intercommunication systems
- Network-, Web- and E-mail-security

Planning & Installation

- Switch programmes, power sockets
- Overvoltage protective device
- Installation-, channel- and delivery systems
- Cables and lines
- Control cabinet -, boxes- and connecting systems
- UPS-technology, power supplies
- Tools, electrical measurement- and testing instruments
- CAD/CAE-systems
- Energy distribution
- Connection technologies (Plug-in connectors, clamps etc.)

Energy & Efficiency

- Solar technology/Solar heat/Photovoltaic
- Regenerative heat recovery
- Smart metering, energy management and consulting
- Thermography /Infrared cameras

Heating, Ventilation & Air Conditioning

- Climate-, refrigeration engineering, ventilation
- Electrical heating systems
- Heat pumps
- Control- and system technology for heating systems

Communication & Multimedia

- Audio/Video/Multiroom
- Home cinema systems/Home entertainment
- Data- and Network technology
- Digital-TV/IP-telephony/Triple play/broadband

Light & Shade

- Lighting technology, light management
- Lamps and lights (inside and outside)
- Light control devices
- Door-, gate- and sun protection automation

Company Management & Staff

- Utility vehicle and vehicle equipment
- Work and working clothes
- Insurances for commercial risks
- Branch-software für electricians

Issue 1+2/2012

2110212012

Editorial deadline:
1810112012

Ad deadline:
2510112012

Material deadline:
0110212012



Series: Future Technology
EeBus

Special topic:
Digital satellite TV



Energy & Efficiency:

- Smart metering and smart home, Energy management and home networking
- **Market overview:** heat pumps
- Control devices for solar systems

Heating, Ventilation & Air Conditioning:

- Heat recovery ventilation
- Heating with sun energy, solar supported climate systems, heat recovery
- Energy efficient pumps and systems for building technology

Planning & Installation:

- **Market overview:** plug-in connectors and clamps
- Measurement technology: clamp-on ammeters, Isolation- and electrical grounding measurement instruments, Power-, Energy- and Network-quality instruments, Infrared measurement

Light & Shade:

- Lighting control with Dali
- Work- and office lightings
- Drive- and control technology for rolling shutters, gates and sunshade

FeuerTRUTZ (Nuremberg)	22.02. - 23.02.12
R + T (Stuttgart)	28.02. - 03.03.12
Facility Management (Frankfurt)	06.03. - 08.03.12
CeBIT (Hannover)	06.03. - 10.03.12
fireprotec (Frankfurt)	07.03. - 08.03.12
SHK (Essen)	07.03. - 10.03.12
Automatisierungstreff (Böblingen)	20.03. - 22.03.12
Prolight + Sound (Frankfurt)	21.03. - 24.03.12
wire (Düsseldorf)	26.03. - 30.03.12
CEP - Clean Energy Power (Stuttgart)	29.03. - 31.03.12
IFH/Intherm (Nuremberg)	18.04. - 21.04.12

Issue 3+4/2012

Special issue Light+Building

2910312012

Editorial deadline:
2810212012

Ad deadline:
0610312012

Material deadline:
1310312012



Series: Future Technology
Organic LEDs (OLEDs)

light+building

Content:

This special publication will give an overview about the newest trends and developments, which will be presented on the Light+Building. The topics of the editorial articles and product news will focus the three key-branches of the integrated building planning:

- Light
- Electrical engineering
- Home- and building automation.

Main topic 2012 is energy efficiency.

More important topics in this issue:

- LED-Technology
- Smart metering
- Security technology
- Photovoltaics
- Installation- and Network technology
- Heating and climate technology
- Software for building industry

Additionally:

- Light+Building guide
- Hall plan
- List of exhibitors
- Background information

Light+Building (Frankfurt)	15.04. - 20.04.12
Hannover Messe (Hannover)	23.04. - 27.04.12
High End (Munich)	03.05. - 06.05.12

Issue 5+6/2012

with special supplement
solar technology
(see page 8)

16I05I2012

Editorial deadline:
20I04I2012

Ad deadline:
26I04I2012

Material deadline:
03I05I2012



Series: Future technologies
Organic solar cells

**Issue 7/2012****10I07I2012**

Editorial deadline:
12I06I2012

Ad deadline:
19I06I2012

Material deadline:
26I06I2012



Series: Future technologies
Visible Light Communication

**Communication & Multimedia:**

- Satellite technology/cable networks
- Hybrid-TV/HbbTV: Television and Internet
- News ANGA Cable trade fair

Light & Shade:

- Professional light planning
- Energy efficient lighting systems
- Sun protection automation via smartphone
- Efficient lighting concepts

Security & Surveillance:

- Burglary alert systems
- Video surveillance: cameras und systems
- Electronical access controll

Home & Building Automation:

- **Market overview:** Panel-PCs for buildings and multimedia
- Connected building automation with LON-technology
- Smart-home-concepts
- Proprietary systems for building automation

Planning & Installation:

- Seal of approval for electrical installation and devices: E-check
- **Market overview:** Cables and lines
- Wiring systems
- Low voltage distribution board

Communication & Multimedia

- Smart TV & videostreaming, 3D-television
- Data center for home networks: NAS (Network Attached Storage)
- Connected household appliances
- News IFA

Security & Surveillance:

- Security in home network
- **Market overview:** door communication systems
- Fire protection/fire alert systems
- Security by smoke detectors

Home- & Building Automation:

- Battery-free radio technology for building automation: EnOcean
- Operational concepts for home automation

innosecure (Velbert)	23.05. - 24.05.12
ANGA Cable (Cologne)	12.06. - 14.06.12
Intersolar Europe (Munich)	13.06. - 15.06.12
ConLife (Cologne)	26.06. - 28.06.12
Sicherheits Expo (Munich)	04.07. - 05.07.12

IFA (Berlin)	31.08. - 05.09.12
--------------	-------------------

Issue 8+9/2012

with special supplement security technology
(see page 8)

1110912012

Editorial deadline:
1410812012

Ad deadline:
2110812012

Material deadline:
2810812012



belektro

Issue 10+11/2012**061112012**

Editorial deadline:
2110912012

Ad deadline:
2710912012

Material deadline:
0211012012



GET Nord



DEADLINES

MAIN TOPICS OF THIS ISSUE

TRADE FAIRS

Planning & Installation:

- Connection technology for building automation
- **Market overview:** uninterrupted power supplies (UPS)
- Climatization of electric control cabinets

Light & Shade:

- LED-technology for indoor- und outdoor lights
- Energy efficient lightings by light management systems

Home- & Building Automation:

- KNX-building technology
Visualisation und controlling
- Radio systems for building control

Energy & Efficiency:

- Energy self-sufficient building
- Intelligent memory systems for solar electricity
- PV-plant monitoring
- Electromobility
- Energy efficient hybrid-heating systems

Planning & Installation:

- **Market overview:** digital multimeter
- Energy distribution
- Special tools and connection technology for Photovoltaics

Home & Building Automation:

- Smart home systems
- Building automation and energy management with BACnet
- News GET Nord trade fair

Communication & Multimedia:

- Phone via Internet: VoIP
- ITK-systems for home and business
- IP-based door communication
- Home entertainment

Company Management & Staff:

- **Market overview:** commercial software solutions
- Network security for small and medium companies

IAA Nutzfahrzeuge (Hannover)	20.09. - 27.09.12
27th EU PVSEC (Frankfurt)	24.09. - 28.09.12
security (Essen)	25.09. - 28.09.12
RENEXPO (Augsburg)	27.09. - 30.09.12
Chillventa (Nuremberg)	09.10. - 11.10.12
belektro (Berlin)	17.10. - 19.10.12
eCarTec (Munich)	23.10. - 25.10.12
SmartHome Conf. & Expo (Ahaus)	08.11. - 09.11.12

GET Nord (Hamburg)	22.11. - 24.11.12
SPS/IPC/DRIVES (Nuremberg)	27.11. - 29.11.12

Issue 12/2012**13112|2012**Editorial deadline:
2610|2012Ad deadline:
0211|2012Material deadline:
0911|2012Series: future technologies
Ambient Assisted Living

Heating, Ventilation & Air Conditioning:

- Planning software for washroom, -sanitary, and heating systems
- Climate- and heating control systems
- Climate control of electronic data processing centers
- Electronical boilers and heat stores

Planning & Installation:

- **Market overview:** CAD/CAE-Systems, electrical planning and documentation
- EMV, overload and lightning protection
- Switch systems

Home & Building Automation:

- Energy management and building control systems
- Room automation: single room and zone control

Energie & Effizienz:

- **Market overview:** inverter modules for Photovoltaics
- Thermal solar systems, heat pumps
- Building-thermography/Energy consulting
- Efficiency-check for administrative buildings, business buildings and production areas

BAU (Munich)	14.01. - 19.01.13
ELTEC (Nuremberg)	16.01. - 18.01.13
enerTEC (Leipzig)	29.01. - 31.01.13
ISE (Amsterdam)	29.01. - 31.01.13

Special supplement solar technology(issue 5+6/2012)
Detailed information,
see page 13**16105|2012**Editorial deadline:
05104|2012Ad deadline:
12104|2012Material deadline:
19104|2012
Topics:

- Photovoltaics
- Solar heat
- **Market overview:** Photovoltaic modules
- News Intersolar including list of exhibitors

Special supplement security technology(issue 8+9/2012)
Detailed information, see page 14**11109|2012**Editorial deadline:
31107|2012Ad deadline:
07108|2012Material deadline:
14108|2012**Topics:**

- Access control systems
- Fire protection
- Alert systems
- Video surveillance
- **Market overview:** network-cameras
- News security trade fair including list of exhibitors

Technical data:

Special size: 175mm x 246mm

1 The **GEBÄUEDIGITAL** informs its readers about all topics concerning recent building technology, always up-to-date and always comprehensive. The regular contents structure the magazine according topics and focus the information inside, which makes it easier for the readers to get the information they want and need. With an increasingly digitalized building technology, the **GEBÄUEDIGITAL** is an ideal platform for current product news, technologies, innovations and concepts, but also for visions and trends. By additional advertisements on our website www.gebaeuedigital.de and in our newsletter **digital home news** the **GEBÄUEDIGITAL** is a unique information media for electrical engineering and for the electrical and building automation business.

- | | | |
|----|---|--|
| 2 | Memberships | None |
| 3 | Organ | – |
| 4 | Publisher | Dipl.-Stat. B. Al-Scheikly |
| 5 | Editorial department | Kai Binder, editor in-chief, Dipl.-Ing. (FH) Henning Schulz, |
| 6 | Advertisements | Richard Sturm, Stefanie Hollinghaus, Konstantin Kiy |
| 7 | Volume | 6th Volume 2012 |
| | Frequency | 7 x a year plus 2 special supplements |
| 8 | Publishing company | Technik-Dokumentations-Verlag GmbH |
| 9 | P.O. Box | Postfach 2140, 35009 Marburg, Germany |
| | Delivery address | Zu den Sandbeeten 2, 35043 Marburg, Germany |
| 10 | Telephone | +49 6421 308-60 |
| | Telefax | +49 6421 308-628 |
| 11 | Internet | www.gebaeuedigital.de |
| | E-mail | info@gebaeuedigital.de |
| 12 | Dates-/topics | see page 4 et seqq. |
| 13 | Purchase prices (from 01.01.2012) | |
| | Annual subscription | Germany € 28,00 (ind. postal charges and tax),
Abroad € 32,00 |
| | Cover price | € 4,80 (ind. postal charges and tax) |
| | ISSN-Nr. | 1864-3353 |
| 14 | Volume analyses | 2010 = 7 issues plus 1 supplement |
| | Format | DIN A4, 210mm (width) x 297mm (height) |
| | Total volume | 568 pages = 100% |
| | Editorial content | 484 pages = 85,2% |
| | Advertisement content | 74 pages = 13,0% |
| | Publishers ads | 6 pages = 1,1% |
| | Inserts | 4 pages = 0,7% |
| | Supplements | 6 |
| 15 | Content analyses of the editorial part, see page 10. | |
| 16 | Circulation control | |

15 Analysis of the editorial content

Home- & Building Automation	103	21,28%
Planning & Installation	80	16,53%
Security & Surveillance	78	16,12%
Energy & Efficiency	62	12,81%
Light & Shade	54	11,16%
Heating/Ventilation/Air Condition	37	7,64%
Communication & Multimedia	33	6,82%
Service	24	4,96%
Company Management & Staff	13	2,69%

16 Circulation control

17 Circulation analysis

Copies per issue from 01st of April to 30th June 2011 (2nd Quarter)

Printed Circulation:	22.500	
Actually Distributed Circulation (ADC)::	22.088	thereof abroad: 336
Sold Circulation:	185	thereof abroad: 26
• Subscribed copies:	191	thereof abroad: 26
• Single sale:	52	
• Returned copies:	58	
Free copies:	21.903	thereof abroad 310
Remaining, archive and voucher copies:	354	



18a Commercial area

Germany	21.752	98,48%
Abroad	336	1,52%
Actually distributed circulation	22.088	100%

18b National distribution by postal code

Postal Code 0	363	1,67%
Postal Code 1	864	4,46%
Postal Code 2	2.047	9,42%
Postal Code 3	2.414	11,38%
Postal Code 4	3.274	14,84%
Postal Code 5	2.979	13,42%
Postal Code 6	2.135	10,48%
Postal Code 7	2.437	12,21%
Postal Code 8	2.600	12,86%
Postal Code 9	2.000	9,26%
Act. distributed circulation	21.752	

Branches

Electrical installation and electrical business:	74,3%
Electrical wholesale:	11,5%
Architects, Engineering consultants, Technical office:	7,8%
other Electrotechnical industry:	3,6%
Instituts, Organisations and Offices:	2,8%

(we will increase the target audience in the branch Climate, Heating- and Air Conditioning up to 5% in 2012)

Our prices
stay the
same!

Size	Width x Height	b/w	2c	3c	4c
1/1 page	185mm x 270mm	€ 4,200,-	€ 4,770,-	€ 5,055,-	€ 5,340,-
2/3 page	120mm x 270mm	€ 2,800,-	€ 3,270,-	€ 3,505,-	€ 3,740,-
1/2 Junior (DIN A5)	140mm x 190mm	€ 2,500,-	€ 2,910,-	€ 3,115,-	€ 3,320,-
1/2 page vertical	90mm x 270mm	€ 2,000,-	€ 2,410,-	€ 2,615,-	€ 2,820,-
1/2 page oblong	185mm x 130mm	€ 2,000,-	€ 2,410,-	€ 2,615,-	€ 2,820,-
1/3 page vertical	60mm x 270mm	€ 1,400,-	€ 1,710,-	€ 1,865,-	€ 2,020,-
1/3 page oblong	185mm x 90mm	€ 1,400,-	€ 1,710,-	€ 1,865,-	€ 2,020,-
1/4 page	90mm x 130mm	€ 1,000,-	€ 1,260,-	€ 1,390,-	€ 1,520,-
1/4 page vertical	45mm x 270mm	€ 1,000,-	€ 1,260,-	€ 1,390,-	€ 1,520,-
1/4 page oblong	185mm x 65mm	€ 1,000,-	€ 1,260,-	€ 1,390,-	€ 1,520,-
1/2 page company presentation (special ad)**	90mm x 270mm		-	-	€ 1,350,-
1/8 page	90mm x 65mm	€ 500,-	€ 695,-	€ 790,-	€ 890,-
1/8 page vertical	45mm x 130mm	€ 500,-	€ 695,-	€ 790,-	€ 890,-
1/8 page oblong	185mm x 30mm	€ 500,-	€ 695,-	€ 790,-	€ 890,-
cover pages	185mm x 270mm	€ 4,900,-	€ 5,470,-	€ 5,755,-	€ 6,040,-

Color-surcharge ¹	1/1 page	2/3 page	1/2 page	1/3 page	1/4 page	1/8 page
2-colored	€ 570,-	€ 470,-	€ 410,-	€ 310,-	€ 260,-	€ 195,-
3-colored	€ 855,-	€ 705,-	€ 615,-	€ 465,-	€ 390,-	€ 290,-
4-colored	€ 1,140,-	€ 940,-	€ 820,-	€ 620,-	€ 520,-	€ 390,-
Special color	€ 770,-	€ 770,-	€ 660,-	€ 660,-	€ 660,-	€ 660,-

Front page	On request
Placing	Extra charge of 10% on the basic price for confirmed placings.
Job advertisement	We grant a 30% discount on the basic price (b/w).
Agency commission	15%
Size surcharges	Advertisements over bending, gutter bleed: 10% surcharge on the basic price
Magazine-size	DIN A4, 210mm x 297mm (width x height)
Print space	185mm x 270mm (width x height)

Colored advertisements are printed according to the Euroscale (CMYK). Alternative colors are regarded as special colors.

* Alle prices are zero rated for VAT.

** Company presentations are designed in a special layout of the GEBÄUEDIGITAL. (see page 16)

¹ No discount given

Bound inserts

80-135g/m ²	4 pages	€ 5,865,-
	8 pages	€ 8,805,-
	12 pages	€ 11,690,-
136-170g/m ²	10% surcharge on the basic price (b/w)	
ab 170g/m ²	15% surcharge on the basic price (b/w)	

Glued postcards are regarded as fixed inserts (see fixed Inserts).

Delivery quantity: 22,800 copies

Delivery: see 'Technical data' page 25 et seqq.

Supplements¹

	per 1,000 Copies	
up to 25g	€ 4,280,-	€ 190,-
up to 50g	€ 6,300,-	€ 280,-
more than 50g	on request	
Delivery quantity	22,800 Copies	

Fixed inserts^{1,2}

Fixed Inserts (up to 5g without gluing)	€ 830,-
Mechanical gluing	€ 860,-
Manual gluing	on request
Delivery quantity	22,800 copies

Delivery: see 'Technical data' on page 25 et. seqq.

Discounts

(in case of purchase
within 12 months)

Frequency	Discount	Quantity	Discount
from 3 ads	5%	from 2 pages	5%
from 6 ads	10%	from 4 pages	10%
from 9 ads	15%	from 8 pages	15%
from 12 ads	20%	from 12 pages	20%

Advertising material

Please read the 'Technical data' on
page 25 et seqq.

**Advertising and
Material deadline**

See 'Publishing schedule' (page 4 et seqq.)

Terms of payment

Payment within 30 days from date of invoice

Bank data

For payments within 8 days we grant a discount of 2%.

Sparkasse Marburg-Biedenkopf:

bank code 533 500 00

account number 103 730 53 20

Postbank Frankfurt/Main:

bank code 500 100 60

account number 5170 30-603

* All prices are zero rated for VAT. ¹ No discount given ² from 1/1-page ad/bound-in insert possible

Special supplement solar technology

in issue 5+6/2012

In the special supplement solar technology all producers and suppliers of this branch can present their products and solutions, before the 'Intersolar Europe 2012', the leading trade fair for solar technology.

Topics:

- Photovoltaics
- Solar heat
- News Intersolar trade fair

Market overview:

- Photovoltaic modules

Additionally in this issue:

- Trade fair guide
- Hall plan
- List of exhibitors
- Background information

16th of May
2012

inter
solar
connecting solar business | EUROPE



Deadlines:

Date of release	16105112
Editorial deadline	05104112
Ad deadline	12104112
Material deadline	19104112

Technical data:

Size 175mm x 246mm

Prices*:

Ads

1/2 page, 4c	€ 1,300,-
1/1 page, 4c	€ 2,500,-

Ad sizes are limited in this issue.

Company-/Product portraits

1/2 page, 4c	€ 1,000,-
1/1page, 4c	€ 1,900,-
2 x 1/1 page, 4c	€ 3,300,-

* All prices are zero rated for VAT.

Special supplement security technology

in issue 8+9/2012

In the special supplement security technology all producers and suppliers of this branch can present their products and solutions, before the 'security 2012', the leading trade fair for security- and fire protection technology.

Content:

- Video surveillance
- Alert systems
- Access control systems
- Fire protection
- News security trade fair

Market overview

- Network-cameras

Additionally in this issue:

- Trade fair guide
- Hall plan
- List of exhibitors
- Background information

11th Sept.
2012



Deadlines:

Date of release	11109112
Editorial deadline	31107112
Ad deadline	07108112
Material deadline	14108112

Technical data:

Size 175mm x 246mm

Prices*:

Ads

1/2 page, 4c	€ 1,300,-
1/1 page, 4c	€ 2,500,-

Ad sizes are limited in this issue.

Company/Product portraits

1/2 page, 4c	€ 1,000,-
1/1 page, 4c	€ 1,900,-
2 x 1/1 page, 4c	€ 3,300,-

* All prices are zero rated for VAT.

Effective advertising, placed in the most suitable subject area for your products!

Every regular section of each **GEBÄUEDIGITAL** issue is devoted to a certain subject. This gives you the opportunity to have your ads placed in the section and alongside the topics that suit you and your products best.

By booking the inside cover story, you will get an even more effective advertising form. You can start a new subject with your advertisement, which is one of the most premium placings inside.

Home- & Building Automation

Heating, Ventilation & Air Conditioning

Security & Surveillance

Communication & Multimedia

Planning & Installation

Light & Shade

Energy & Efficiency

Company Management & Staff



Your advertisement directly placed in the topic

Price*

Inside cover story

€ 3,500,-

* All prices are zero rated for VAT.

Company portraits/ Product portraits

... the special ad!



1/2 page (about 1.400 characters)



1/1 page (about 2.800 characters)

Layout with company logo
company pictures, address,
company profiles, products, etc.

Prices *
1/1 page € 2,500,-
1/2 page € 1,350,-

We will do the layout for you – without additional costs!

The material checklist:

- Contact information – Phone, Fax, Web-Address, E-mail
- Logo – Please send your digitalized/vector based logo
- Product image – We need your product image in at least 300dpi
- Text – Word and other text files, like RTF-, DOC, etc.

* All prices are zero rated for VAT.

Banderole

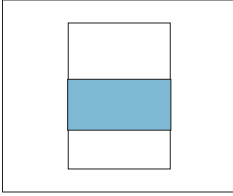

Affixed postcard

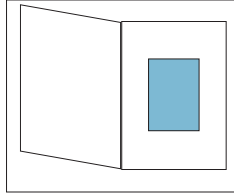

Supplement

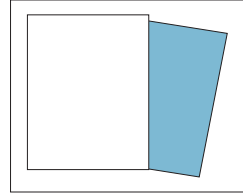

Gatefolder

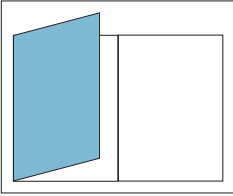

Half cover

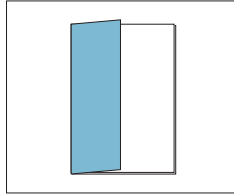

CD-ROM

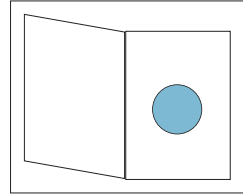

Reprint

The reprint of technical contributions, interviews and product information is a useful opportunity to support your product and brand messages in the market at a reasonable price.

We do the print, the creation of an electronic file for your web presence and on request the distribution via our lettershop.



Price list*

2 pages, 4-colours, 135g/m ²	
Circulation	Price
500	€ 660,-
1,000	€ 700,-
2,000	€ 785,-
5,000	€ 1,070,-
10,000	€ 1,840,-

4 pages, 4-colours, 135g/m ²	
Circulation	Price
500	€ 735,-
1,000	€ 770,-
2,000	€ 885,-
5,000	€ 1,260,-
10,000	€ 1,825,-

* All prices are zero rated for VAT.

New special placements

Present your company with a special flair in exclusive placements in the table of contents, in our new section 'producers' or in our market place.

Placements in the table of contents



Prices*:

1/4 p. oblong, 4c	€ 1,750,-
1/4 p. oblong, 4c (on two pages)	€ 3,400,-
1/8 p. oblong, 4c	€ 1,050,-
1/8 p.oblong, 4c (on two pages)	€ 2,000,-

Address item in the section 'producers'



- Address item in all regular 7 print issues (duration 12 months)
- alphabetical order
- additionally on www.gebaeuedigital.de
- Price for 7 issues: € 350,-

Market place

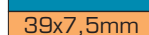
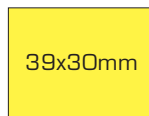
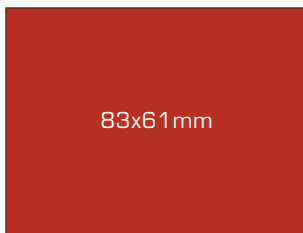

Prices*:

83mm x 61mm	€ 400,-
39mm x 30mm	€ 200,-
39mm x 15mm	€ 100,-
39mm x 7,5mm	€ 50,-

* Alle prices are zero rated for VAT.



digital home news

GEBÄUEDIGITAL Newsletter

Ad sizes

Headline special size
 (132mm x 25mm)
 (only first and last page)

Ad Topic
 (63mm x 70mm)

Ad Bottom
 (200mm x 25mm)

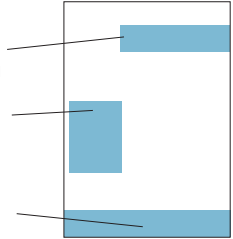

Prices*

Frequency	Discount	Premium	Standard	Advertorial
		page 1	from page 2	special size, page 2 only (132mm x 85mm)
1	0 %	€ 680,-	€ 600,-	€ 720,-
3	5 %	€ 646,-	€ 570,-	€ 684,-
5	10 %	€ 612,-	€ 540,-	€ 648,-
10	20 %	€ 544,-	€ 480,-	€ 578,-

Contents:

- News/Trends
- Trade fair information
- Company-news
- Business-news
- and more

Release dates 2012

January	February	March	April	May	June
26I01I2012	09I02I2012	08I03I2012	05I04I2012*	03I05I2012	14I06I2012
	23I02I2012	22I03I2012*	19I04I2012	16I05I2012*	28I06I2012
				31I05I2012*	
July	August	September	October	November	December
12I07I2012	09I08I2012	06I09I2012*	04I10I2012	01I11I2012	13I12I2012
26I07I2012	23I08I2012	20I09I2012*	18I10I2012	15I11I2012	
				29I11I2012	

* Special newsletter to following events: March/April 2012: Light+Building
 May 2012: ANGA Cable, Intersolar Europe
 September 2012: security trade fair

Payment

Invoicing follows ad placement. Payment within 14 days of invoice.
 For payment within 7 days of invoice we grant a discount of 2%.

Material delivery

PDF or EPS (RGB-colours) with embedded fonts resp. changed in paths.

* All prices are zero rated for VAT.

www.gebaeuedigital.de



1. Daily updated news



2. All contents of the GD



3. Market overviews



4. Product catalogue



5. Producers



6. News



7. Event calendar



8. TeDo-Online-Shop



Banner sizes and prices* (per months)

Banner	Size (Pixel)	Description	Price/Month
1. Fullsize-Banner	468 x 60	Integrated prominently placing in the heading section of the website	€ 450,-
2. Skyscraper	160 x 600	Portrait advertisement space right beside the content	€ 550,-
3. Expandable-Skyscraper	160 x 600 300 x 600 expanded	Not only long in the users focus, also interactive per Mouse-over	€ 1,250,-
4. Super-Banner	728 x 90	Prominently placed at the heading section with lots of space for your product presentations	€ 1,000,-
5. Expandable Super-Banner	728 x 90 728 x 160 expanded	A whole lot more space for your product presentations in the eye-catching heading section	€ 1,450,-
6. Content-AD/Rectangle	300 x 250	Outstanding in the editorial content big enough for the most creative advertisements	on request
7. Expandable Content-AD	300 x 250 300 x 500 expanded	Outstanding in the editorial content big enough for the most creative advertisements	on request
8. Wallpaper	728 x 90 160 x 600	Combine the advantages of Skyscraper and Super-banner. You can even define the background colour	€ 1,850,-
9. Standard Top	170 x 60	Smaller ad space in the heading section or content	€ 350,-
10. Sidebar-Banner	170 x 140	Smaller ad space right beside the content	€ 400,-

* All prices are zero rated for VAT.

1. Fullsize-Banner



3. Skyscraper



2. Expandable-Skyscraper



4. Super-Banner



5. Expandable Super-Banner



6. Content-AD/Rectangle



7. Expandable Content-AD



8. Wallpaper



9. Standard Top



10. Sidebar-Banner



Here everything is about you!



Present the following tools:

Editorial articles



Editorial articles, which have been published in the **GEBÄUEDIGITAL** print issues will be listed here and can be accessed easily by the users. Of course this service is administrated automatically.

News + Details

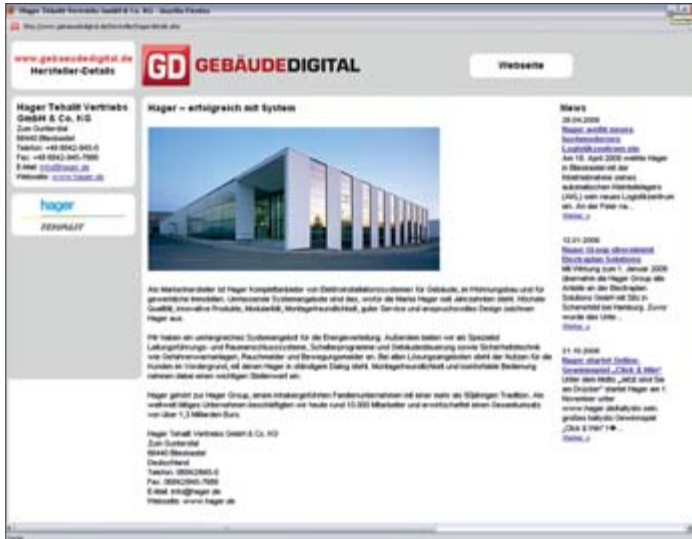

Present your products to your target group on our 'producers microsities'. With access at any time, the whole year – for a fair price. You will reach your whole target group and get a unique combination of Print and Online. On your microsite you can present your company or your products. Additionally you can present your news. You can update and change the contents of your microsite at any time.

The advantages of the producers microsities **GEBÄUEDIGITAL** :

- Your products will be presented to your target audience.
- Available 365 days a year.
- For a fair price.
- You will reach your whole target audience with a unique combination of print and online.
- On your microsite you can either present your company or your products. Even both is possible!
- You can update and change the content of your site at any time!

Price: € 1,490,- for 12 Months

Place your company logo in a special section



In each branch section on www.gebaeuedigital.de you can place your company logo for a reasonable price.

By doing this, you are in the direct focus of our users and visitors.

**Price: € 600,-
for 12 months**

- Your logo in your preferred section on www.gebaeuedigital.de
- Online at any time in the suitable editorial part
- Your logo will be linked with your internet site
- Duration: 12 months

(It is limited to max. 4 logos per section)

Size format print space (width x height)

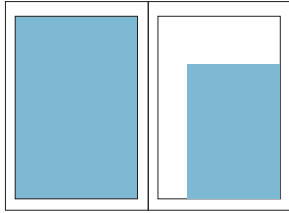

1/1 page
185mm x 270mm

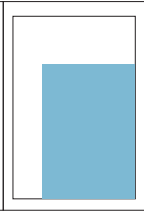

1/2 page A5 (junior)
140mm x 190mm

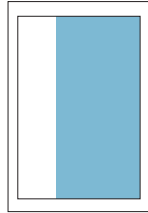

2/3 page vertical
120mm x 270mm
2/3 page oblong
185mm x 180mm

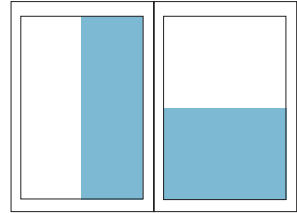

1/2 page vertical
90mm x 270mm

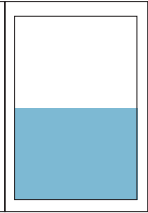

1/2 page oblong
185mm x 130mm

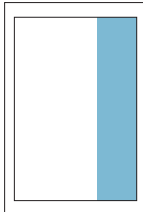

1/3 page vertical
60mm x 270mm

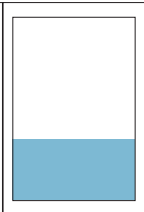

1/3 page oblong
185mm x 90mm

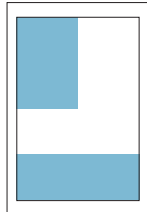

1/4 page oblong
185mm x 65mm
1/4 page
90mm x 130mm

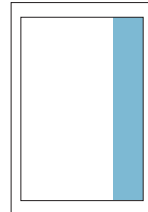

1/4 page vertical
45mm x 270mm

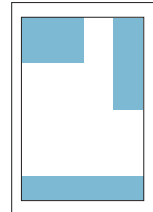

1/8 page oblong
185mm x 30mm
1/8 page vertical
45mm x 130mm
1/8 page
90mm x 65mm

Size format with bleed (width x height)

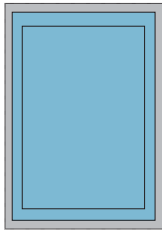

1/1 page
210mm x 297mm

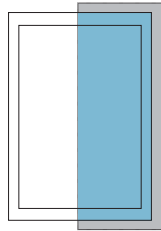

1/2 page vertical
105mm x 297mm
1/2 page oblong
210mm x 148mm

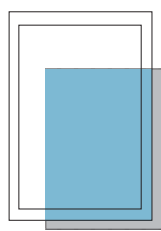

1/2 page A5 (junior)
148mm x 210mm

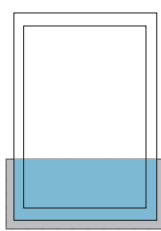

1/3 page oblong
210mm x 100mm
1/3 page vertical
70mm x 297mm

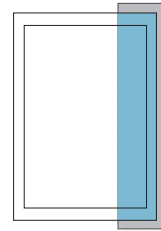

1/4 page vertical
52mm x 297mm
1/4 page oblong
210mm x 74mm
1/4 page
105mm x 148mm

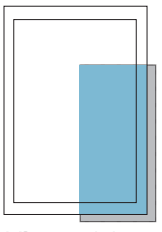

1/8 page vertical
52mm x 148mm

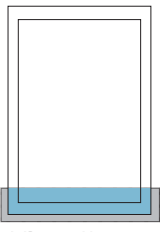

1/8 page oblong
210mm x 39mm

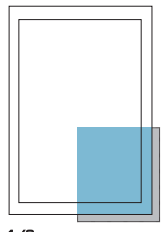

1/8 page
105mm x 74mm

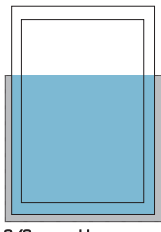

2/3 page oblong
210mm x 198mm

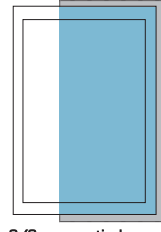

2/3 page vertical
140mm x 297mm

Printing material

Printing process	Offset: Printing colors in Euroscale (CMYK) for offset according to DIN 16 539
Magazine format	DIN A4 – 210mm x 297mm (width x height)
Print space	185mm x 270mm (width x height)
Delivery	Mail: GEBÄUEDIGITAL, Anzeigendisposition, Postfach 2140, 35009 Marburg, Germany Courier mail service: GEBÄUEDIGITAL, Anzeigendisposition, Zu den Sandbeeten 2, 35043 Marburg, Germany
Delivery date	The date of delivery is the material deadline of the particular issue (see publishing schedule, page 4ff.)
Printing data	High-Res-PDF, EPS (fonts converted into paths, or embedded) TIFF (resolution 300dpi)
Data carrier	CD-ROM
Proof	When printing colored advertisements a binding proof/printout is required to assure the authenticity of colors. Without these documents we do not guarantee color fastness. The publisher gives no guarantee for color deviations effected by using different papers. The same applies to deviations that vary within the tolerance of industrial color printing or as a result of the offset process.
Color profiles	Please do not use color profiles!
Return	Material is only returned by special request of the customer. The storage obligation ends three months after the advertisement has been published.
Warranty/ additional expenditure	Only data existing on the data carrier can be exposed. The publisher assumes no liability for deviances in texts, illustrations and especially in colors. Misexposures effected by incomplete or defective files, misadjustment or incomplete information are charged by expenditure. Positive patterns being sent must be digitised and the customer is charged separately for the additional work.

Advertisement material transfer

E-Mail	anzeigen@gebauedigital.de
---------------	---------------------------

Systems/Programs

For PC/MAC	QuarkXPress, InDesign, Illustrator, Photoshop
Colors	Printing in four colors we use Cyan, Magenta, Yellow, Black (CMYK) as defined through the Euroscale. It is absolutely necessary to choose this color area in the programs. Attention: We cannot use colors defined in the RGB color area or spot colors.
Graphic data	If there are graphic elements or scans in the advertisement, those imports need to be attached. Graphic and image data need additional saving in their original programmes separately on the data carrier. Accepted formats for image data: TIFF, JPEG, EPS (with embedded fonts).

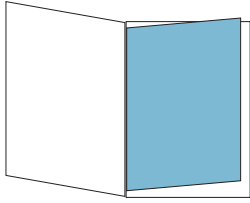

Supplement

Minimal size	147mm x 210mm
Maximum size	210mm x 297mm
Minimal weight	for 4-pages products 115g/m ² (2-paged products on request)

Before the order is accepted and confirmed, we require a copy of a binding sample with an indication of size and weight. The bound-in inserts are to be delivered without cuttings on the bleeds, multisheet bound-in inserts or those with flap are to be delivered folded. The front page of the bound-in inserts needs to be marked.

Placing between two parts of one sheet of paper.

Multipage bound-in inserts need to be delivered folded and in an uncut format.

Cut pages, also within the gutter, need a 5mm margin per cut page.

4 pages bound-in

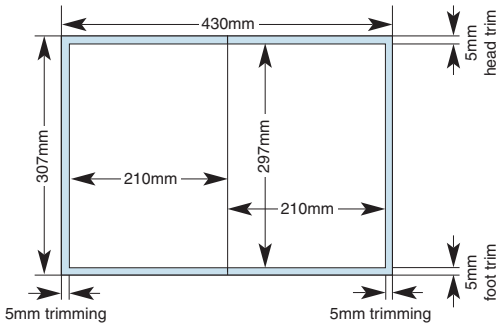

4 pages bound-in with cover

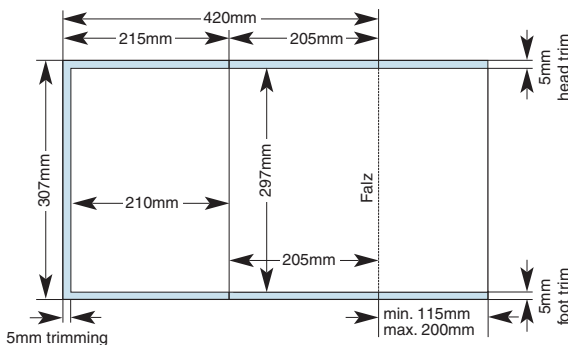

Loose inserts

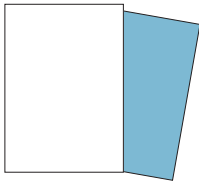

Minimal format	100mm x 210mm
Maximal format	205mm x 290mm
Minimal weight	115g/m ²
Maximal weight	by request
Positioning	undefined

Before the order is accepted and confirmed, we require a copy of a binding sample with an indication of size and weight.

We need the inserts trimmed and clinched as final products.

Fixed inserts

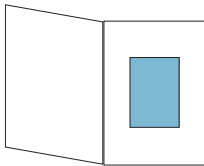

Minimal format	105mm x 147mm
Maximal format	148mm x 190mm
Minimal weight	160g/m ²

Mechanical gluing: Glued edge is fixed parallel to the flange, at least 10mm to maximal 60mm from the flange. Folded items need closing at the flange. Positioning on request. Affixed postcards, product samples on bound inserts or full-paged advertisements we additional charge as a fixed insert. Before the order is accepted and confirmed we require a copy of a binding sample with an indication of size and weight.

Delivery

The delivery of any bound-in inserts and fixed inserts always requires a delivery note. To guarantee an unobstructed production, please fix a sample of the content on the pallet's outside. Please send an additional sample to the publisher.

Delivery quantity	22,800 copies
Delivery address	The delivery address for bound-in inserts and any supplements will be given to you together with the confirmation.
Delivery deadline	The printing material deadline is the material delivery deadline for the issue.

- Ziffer 1:** „Anzeigenauftrag“ im Sinn der nachfolgenden Allgemeinen Geschäftsbedingungen ist der Vertrag über die Veröffentlichung einer oder mehrerer Anzeigen eines Werbungtreibenden oder sonstigen Inserenten in Druckschriften des Verlages oder der Vertrag über die Veröffentlichung von Beilagen oder Einheftern zu solchen Druckschriften zum Zweck der Verbreitung.
- Ziffer 2:** Anzeigen sind im Zweifel zur Veröffentlichung innerhalb eines Jahres nach Vertragsabschluss abzurufen. Ist im Rahmen eines Abschlusses das Recht zum Abruf einzelner Anzeigen eingeräumt, so ist der Auftrag innerhalb eines Jahres seit Erscheinen der ersten Anzeige abzuwickeln, sofern die erste Anzeige innerhalb der in Satz 1 genannten Frist abgerufen und veröffentlicht wird.
- Ziffer 3:** Bei Abschlüssen ist der Auftraggeber berechtigt, innerhalb der vereinbarten bzw. der in Ziffer 2 genannten Frist auch über die im Auftrag genannte Anzeigenmenge hinaus weitere Anzeigen abzurufen.
- Ziffer 4:** Wird ein Auftrag aus Umständen nicht erfüllt, die der Verlag nicht zu vertreten hat, so hat der Auftraggeber, unbeschadet etwaiger weiterer Rechtspflichten, den Unterschied zwischen dem gewährten und dem der tatsächlichen Abnahme entsprechenden Nachlass dem Verlag zu erstatten. Die Erstattung entfällt, wenn die Nichterfüllung auf höherer Gewalt im Risikobereich des Verlages beruht.
- Ziffer 5:** Aufträge für Anzeigen, Einhefter und Fremdbeilagen, die erklärtermaßen ausschließlich in bestimmten Nummern, bestimmten Ausgaben oder an bestimmten Plätzen der Druckschrift veröffentlicht werden sollen, müssen so rechtzeitig beim Verlag eingehen, dass dem Auftraggeber noch vor Anzeigenschluss mitgeteilt werden kann, wenn der Auftrag auf diese Weise nicht auszuführen ist.
- Ziffer 6:** Anzeigen werden an bestimmten Positionen nur aufgenommen, wenn diese Sonderplatzierungen jeweils vom Verlag schriftlich bestätigt wurden.
- Ziffer 7:** Abbestellungen von Anzeigen müssen bis zum Anzeigenschluss schriftlich erfolgen. Eine Stornierung nach dem Anzeigenschlussstermin ist nicht möglich. Die Anzeige wird somit in voller Höhe des vereinbarten Anzeigenpreises berechnet. Der Verlag kann die entstandenen Satz- und Produktionskosten dem Auftraggeber in Rechnung stellen. Für Print- und Online-Anzeigen mit Sonderplatzierungen (auch Umschlagseiten, Sonderformate und Produktübersichten) sowie für Titel- und Innentitelseiten besteht kein Rücktrittsrecht. Abbestellung von Online-Anzeigen müssen vier Wochen vor Schaltungsbeginn schriftlich erfolgen. Eine Stornierung von weniger als vier Wochen vor Schaltungsbeginn ist nicht möglich. Die Anzeige wird somit in voller Höhe des vereinbarten Anzeigenpreises berechnet.
- Ziffer 8:** Der Verlag behält sich vor, Anzeigenaufträge – auch einzelne Abrufe im Rahmen eines Abschlusses – und Beilagenaufträge wegen ihres Inhalts, der Herkunft oder der technischen Form nach einheitlichen, sachlich gerechtfertigten Grundsätzen des Verlages abzulehnen, wenn deren Inhalt gegen Gesetze oder behördliche Bestimmungen verstößt oder deren Veröffentlichung durch den Verlag unzumutbar ist. Dies gilt auch für Aufträge, die bei Geschäftsstellen, Annahmestellen oder Vertretern aufgegeben werden. Beilagenaufträge sind für den Verlag erst nach Vorlage eines Modells der Beilage und deren Billigung bindend. Beilagen, die durch Format oder Aufmachung beim Leser den Eindruck eines Bestandteils der Zeitung oder Zeitschrift erwecken oder Fremdanzeigen enthalten, werden nicht angenommen.
- Ziffer 9:** Für die rechtzeitige Lieferung des Anzeigentextes und einwandfreier Druckunterlagen oder der Beilagen ist der Auftraggeber verantwortlich. Für erkennbar ungeeignete oder beschädigte Druckunterlagen fordert der Verlag unverzüglich Ersatz an. Der Verlag gewährleistet die für den belegten Titel übliche Druckqualität im Rahmen der durch die Druckunterlagen gegebenen Möglichkeiten. Für den Verlag entstandene Schäden, durch das nicht rechtzeitige Einreichen von Druckunterlagen, sind vom Auftraggeber zu leisten.
- Ziffer 10:** Der Auftraggeber hat bei ganz oder teilweise unleserlichem, unrichtigem oder bei unvollständigem Abdruck der Anzeige Anspruch auf Zahlungsminderung oder eine einwandfreie Ersatzanzeige, aber nur in dem Ausmaß, in dem der Zweck der Anzeige beeinträchtigt wurde. Lässt der Verlag eine ihm hierfür gestellte angemessene Frist verstreichen oder ist die Ersatzanzeige erneut nicht einwandfrei, so hat der Auftraggeber ein Recht auf Zahlungsminderung. Schadensersatzansprüche aus positiver Forderungsverletzung, Verschulden bei Vertragsabschluss und unerlaubter Handlung sind – auch bei telefonischer Auftragserteilung – ausgeschlossen; Schadensersatzansprüche aus Unmöglichkeit der Leistung und Verzug sind beschränkt auf Ersatz des vorhersehbaren Schadens und auf das für die betreffende Anzeige oder Beilage zu zahlende Entgelt. Dies gilt nicht für Vorsatz und grobe Fahrlässigkeit des Verlegers, seines gesetzlichen Vertreters und seines Erfüllungsgehilfen. Eine Haftung des Verlages für Schäden wegen des Fehlens zugesicherter Eigenschaften bleibt unberührt. Für Fehler jeder Art aus telefonischer Übermittlung haftet der Verlag nur bei Vorsatz oder grober Fahrlässigkeit. Im kaufmännischen Geschäftsverkehr haftet der Verlag darüber hinaus auch nicht für grobe Fahrlässigkeit von Erfüllungsgehilfen; in den übrigen Fällen ist gegenüber Kaufleuten die Haftung für grobe Fahrlässigkeit dem Umfang nach auf den voraussehbaren Schaden bis zur Höhe des betreffenden Anzeigenentgelts beschränkt. Reklamationen müssen – außer bei nicht offensichtlichen Mängeln – innerhalb von vier Wochen nach Eingang der Rechnung und Beleg geltend gemacht werden.
- Ziffer 11:** Werden Anzeigenmotive vom Auftraggeber digital übermittelt, so ist die Haftung des Verlages für ganz oder teilweise unleserliche, unrichtige oder unvollständige Wiedergaben der entsprechenden Anzeigen ausgeschlossen.
- Ziffer 12:** Für vom Auftraggeber bereitgestelltes Material (Einhefter, Beilagen usw.) übernimmt der Verlag keine Gewähr für die Richtigkeit der als geliefert bezeichneten Mengen oder Qualitäten.
- Ziffer 13:** Probeabzüge werden nur auf ausdrücklichen Wunsch geliefert. Der Auftraggeber trägt die Verantwortung für die Richtigkeit der zurückgesandten Probeabzüge. Der Verlag berücksichtigt alle Fehlerkorrekturen, die ihm innerhalb der bei der Übersendung des Probeabzuges gesetzten Frist mitgeteilt werden.
- Ziffer 14:** Sind keine besonderen Größenvorschriften gegeben, so wird die nach Art der Anzeige übliche, tatsächliche Abdruckhöhe der Berechnung zugrunde gelegt.
- Ziffer 15:** Falls der Auftraggeber nicht Vorauszahlung leistet, wird die Rechnung sofort, möglichst aber 14 Tage nach Veröffentlichung der Anzeige, übersandt. Die Rechnung ist innerhalb der aus der Preisliste ersichtlichen, vom Empfang der Rechnung an laufenden Frist zu bezahlen, sofern nicht im einzelnen Fall eine andere Zahlungsfrist oder Vorauszahlung vereinbart ist. Etwaige Nachlässe für vorzeitige Zahlung werden nach der Preisliste gewährt.
- Ziffer 16:** Bei Zahlungsverzug oder Stundung werden Zinsen sowie die Einziehungskosten berechnet. Der Verlag kann bei Zahlungsverzug die weitere Ausführung des laufenden Auftrages bis zur Bezahlung zurückstellen und für die restlichen Anzeigen Vorauszahlung verlangen. Bei Vorliegen begründeter Zweifel an der Zahlungsfähigkeit des Auftraggebers ist der Verlag berechtigt, auch während der Laufzeit eines Anzeigenabschlusses das Erscheinen weiterer Anzeigen ohne Rücksicht auf ein ursprünglich vereinbartes Zahlungsziel von der Vorauszahlung des Betrages und von dem Ausgleich offestehender Rechnungsbeträge abhängig zu machen.
- Ziffer 17:** Der Verlag liefert mit der Rechnung auf Wunsch einen Anzeigenbeleg. Je nach Art und Umfang des Anzeigenauftrages werden Anzeigenausschnitte, Belegseiten oder vollständige Belegnummern geliefert. Kann ein Beleg nicht mehr beschafft werden, so tritt an seine Stelle eine rechtsverbindliche Bescheinigung des Verlages über die Veröffentlichung und Verbreitung der Anzeige.
- Ziffer 18:** Kosten für die Anfertigung bestellter Druckvorlagen sowie für vom Auftraggeber gewünschte oder zu vertretende erhebliche Änderungen ursprünglich vereinbarter Ausführungen hat der Auftraggeber zu tragen.
- Ziffer 19:** Bei Ziffernanzeigen werden der Verlag für die Verwahrung und rechtzeitige Weitergabe der Angebote die Sorgfalt eines ordentlichen Kaufmanns an, Einschreibebriefe und Einbriefe auf Ziffernanzeigen werden nur auf dem normalen Postweg weitergeleitet. Die Eingänge auf Ziffernanzeigen werden vier Wochen aufbewahrt. Zuschriften, die in dieser Frist nicht abgeholt werden, werden vernichtet. Wertvolle Unterlagen sendet der Verlag zurück, ohne dazu verpflichtet zu sein. Der Verlag behält sich im Interesse und zum Schutz des Kunden das Recht vor, die eingehenden Angebote zur Ausschaltung von Missbrauch des Zifferdienstes aus Prüfzwecken zu öffnen. Zur Weiterleitung von geschäftlichen Anpreisungen und Vermittlungsangeboten ist der Verlag nicht verpflichtet.
- Ziffer 20:** CDs werden nur auf besondere Anforderung an den Auftraggeber zurückgesandt. Die Pflicht zur Aufbewahrung endet drei Monate nach Ablauf des Auftrages.
- Ziffer 21:** Werbungsmittler und Werbeagenturen sind verpflichtet, sich in ihren Angeboten, Verträgen und Abrechnungen mit den Werbungtreibenden an die Preisliste des Verlages zu halten. Die vom Verlag gewährte Mittlergebühr darf an den Kunden weder ganz noch teilweise weitergegeben werden.
- Ziffer 22:** Erfüllungsort und Gerichtsstand ist der Sitz des Verlages. Soweit Ansprüche des Verlages nicht im Mahnverfahren geltend gemacht werden, bestimmt sich der Gerichtsstand bei Nichtkaufleuten nach deren Wohnsitz. Ist der Wohnsitz oder gewöhnliche Aufenthalt des Auftraggebers zum Zeitpunkt seiner Klageerhebung unbekannt oder hat der Auftraggeber nach Vertragsabschluss seinen Wohnsitz oder gewöhnlichen Aufenthalt aus dem Geltungsbereich des Gesetzes gelegt, ist als Gerichtsstand der Sitz des Verlages vereinbart.
- Ziffer 23:** Bei teilweiser oder gänzlicher Unwirksamkeit einzelner Bestimmungen bleibt die Gültigkeit der übrigen Bestimmungen unberührt.



GEBÄUEDIGITAL

Electrical installation and building technology in the 21st century

TeDo-Verlag GmbH
GEBÄUEDIGITAL
Postfach 2140
35009 Marburg
Zu den Sandbeeten 2
35043 Marburg
Germany
Phone: +49 64 21 308-60
Fax: +49 64 21 308-628
www.gebaeuedigital.de
info@gebaeuedigital.de



www.gebaeuedigital.de